

CM 90S4 *serie performance*

Gru idraulica a montaggio rapido

Gru automontanti - CM90S4

 Nessun componente elettrico sul braccio e sulle parti alte della gru
No electrical component on the jib and the top of the crane

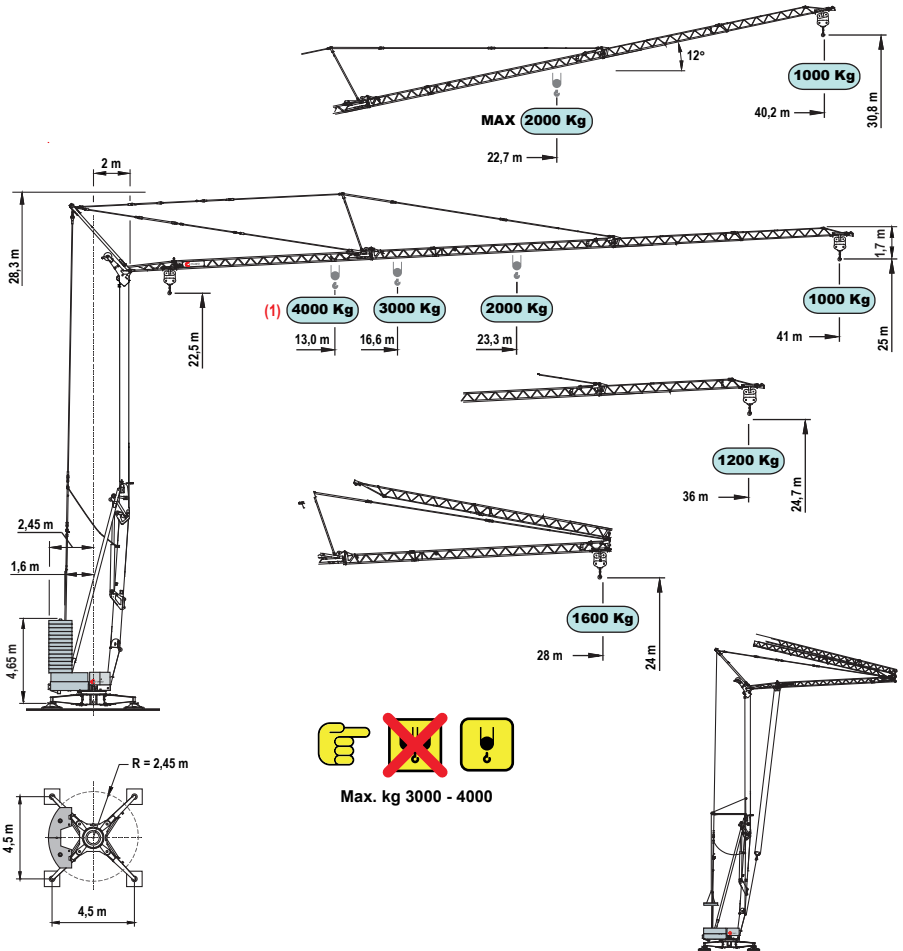

Curve di carico

kg	4000	3000	2500	2000	1900	1800	1700	1600	1500	1400	1300	1200	1100	1000
m	13.0	16.6	19.3	23.3	24.2	25.3	26.5	27.9	29.4	31.1	33.1	35.5	37.8	41.0
m	13.1	16.9	19.6	23.6	24.6	25.8	27.0	28.4	30.0	31.7	33.7	36.0		
m	13.0	16.6	19.4	23.3	24.3	25.4	26.6	28.0						
m				22.7	23.7	24.8	26.0	27.4	28.8	30.5	32.4	34.6	37.0	40.2

Prestazioni

	 kW	 400V - 50Hz	16 kW				
			(1) 21 kW				
	kW/g/min		1°	2°	3°	4°	
		m/min	4	20	35	50	
	(1)	kg		3000	3000	1500	1000
				4000	4000	2000	1500
	inverter	3/1400	m/min 10 - 25 - 50				
	inverter	3,7/900	g/min 0,2 - 0,5 - 0,9				

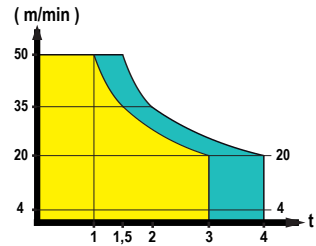

(1) Optional

Contrappeso in lastre di cemento armato

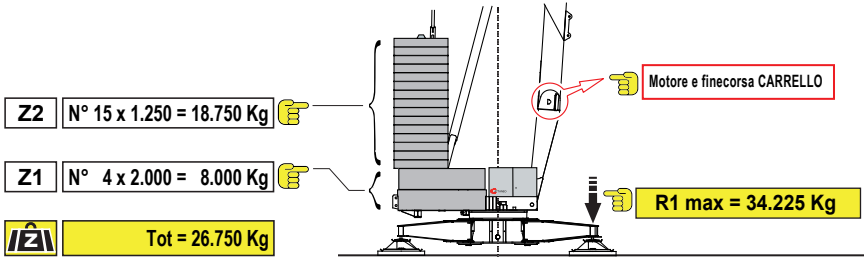

Trasporto

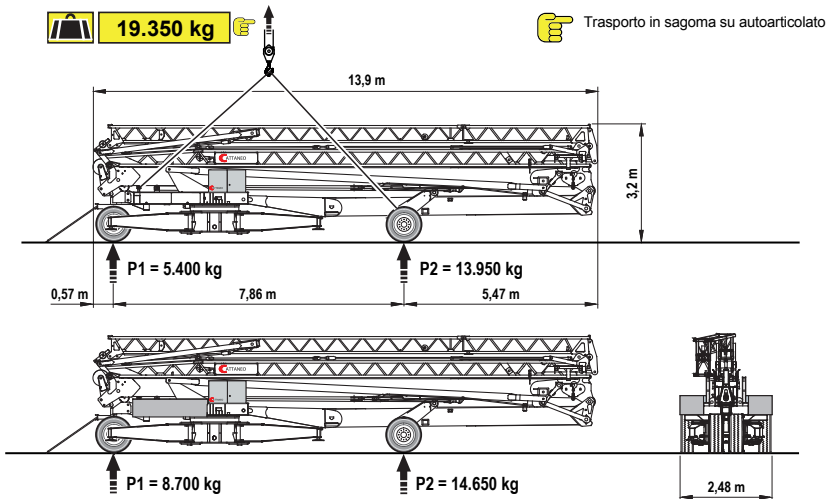

Specifiche suscettibili di variazioni senza preavviso